

HERCULES

Blast Resistant 4H Fire Rated Steel Doors

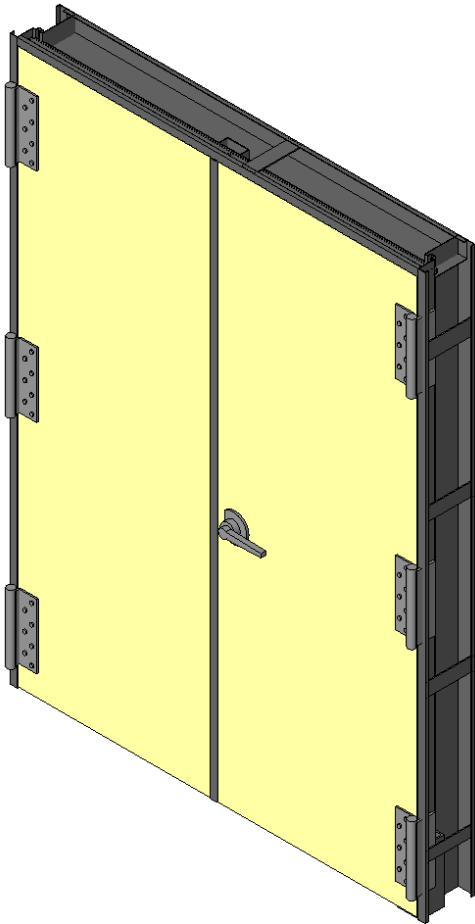

Blast Rating: Up to 495kPa over 4.44 ms, supported by physical blast evidence and PE calculations

Fire Rating: Up to 4 hours, under BS 476:Part 22:1987; SS 332:2007; EN1634.

Panel: PE Design calculated to meet Blast Rating.

Hardware: *Proprietary Tacam multi-point lockset, heavy duty hinges and flushbolt.*

Finish: Primer coat only unless otherwise specified.

Weight: Leaf ~150kg/m².

Max. Sizes: *Single Leaf* 1,000 x 2,780 mm
Double Leaf 2,000 x 2,200 mm

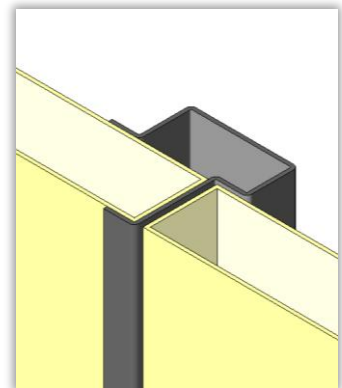
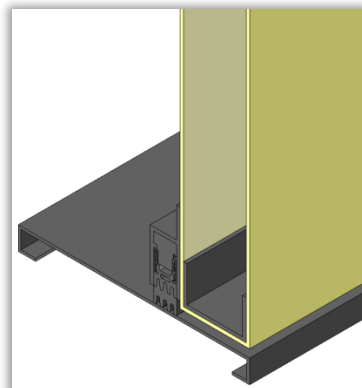
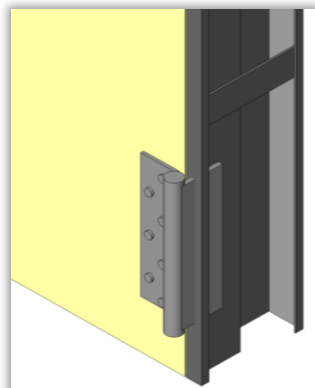
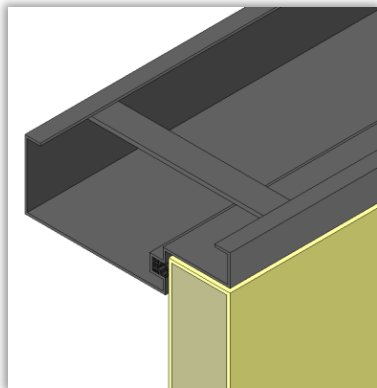

HERCULES

Blast Resistant 4H Fire Rated Steel Doors

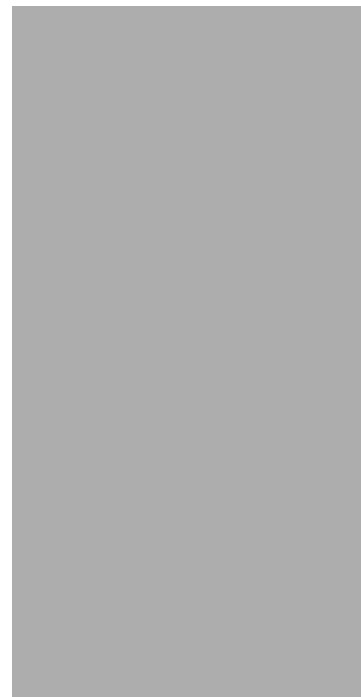

TACAM STEEL PTE LTD