

DOUBLE EGRESS

3H Fire Rated Double-Egress Steel Doors

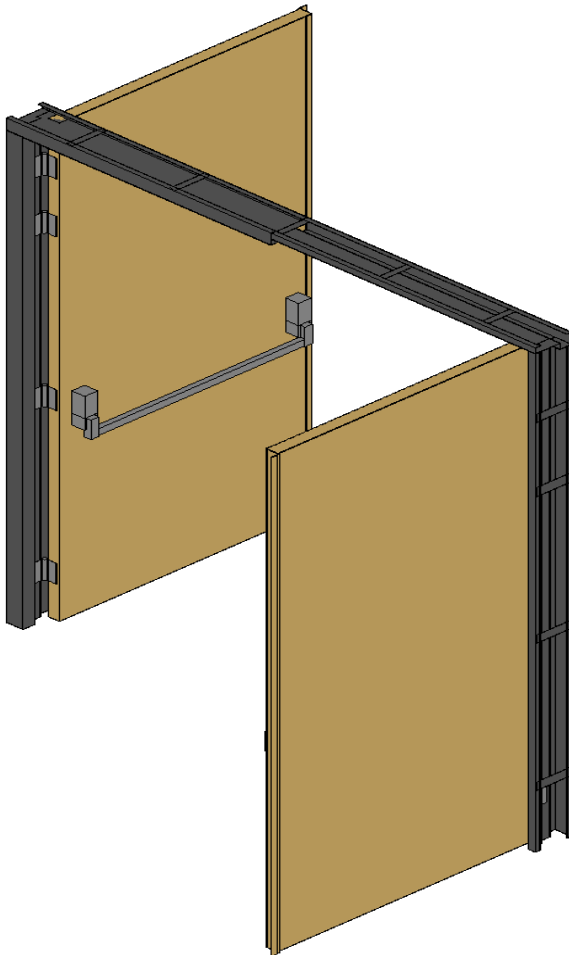

Fire Rating: Up to 3 hours, under BS 476:Part 22:1987; SS 332:2007; EN1634

Doorleaf: 50 mm thick door-leaves formed from 1.5 mm electrogalvanised (zinc-coated) steel skins constructed with a proprietary core,

Frame: Frames are formed from 1.5-2.0 mm electrogalvanised (zinc-coated) steel,

Finish: Primer coat only unless otherwise specified.

Hardware: Standard hardware included for each panel or door leaf are: 3 nos heavy duty hinges, an externally mounted vertical rod panic exit device with horizontal pushbar and heavy-duty door closer.

Weight: ~51 Kg/m²

Max. Size *Double Leaf* 2,000 x 2,155 mm
Vision Panel 100 x 600 mm (up to 2H FR)

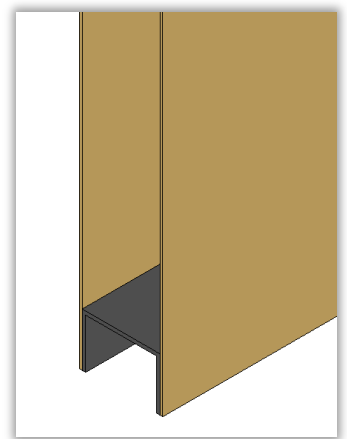
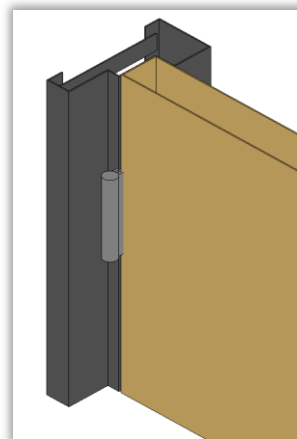
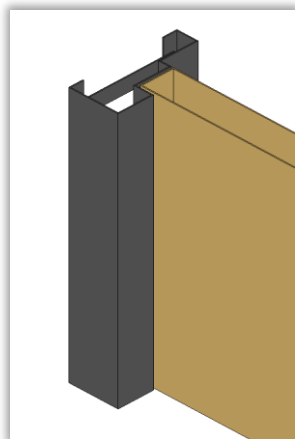
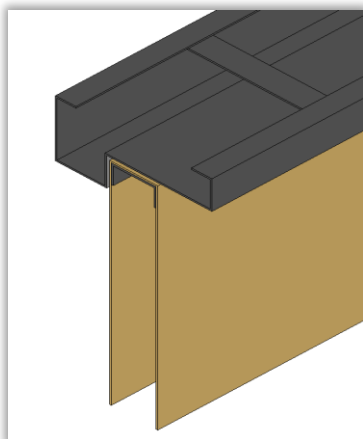

DOUBLE EGRESS

3H Fire Rated Double-Egress Steel Doors



Engineered Door Solutions

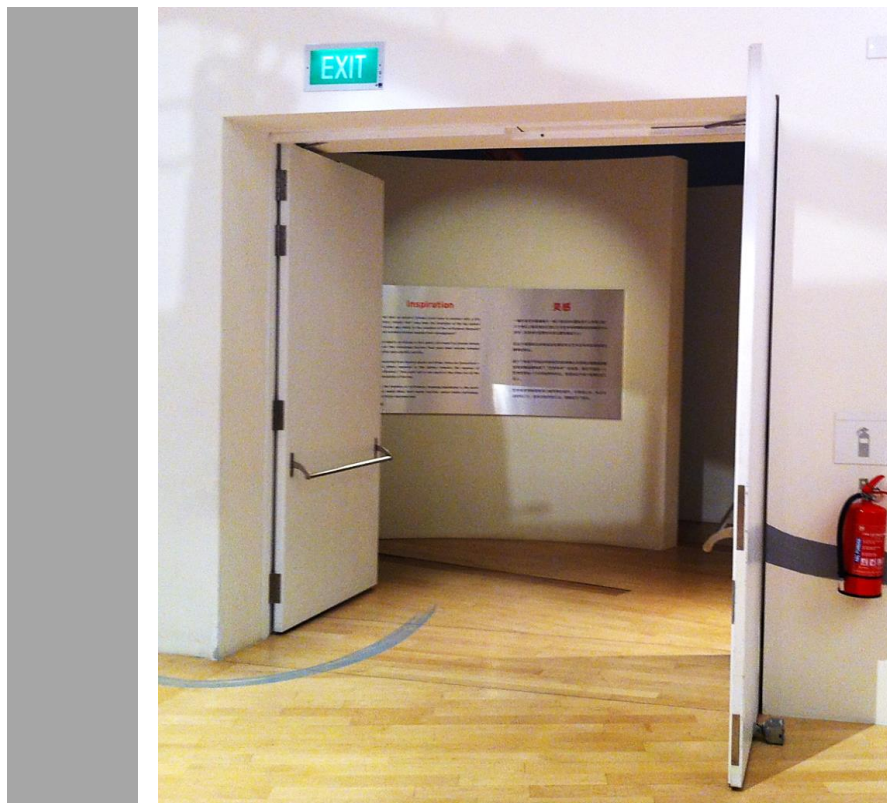
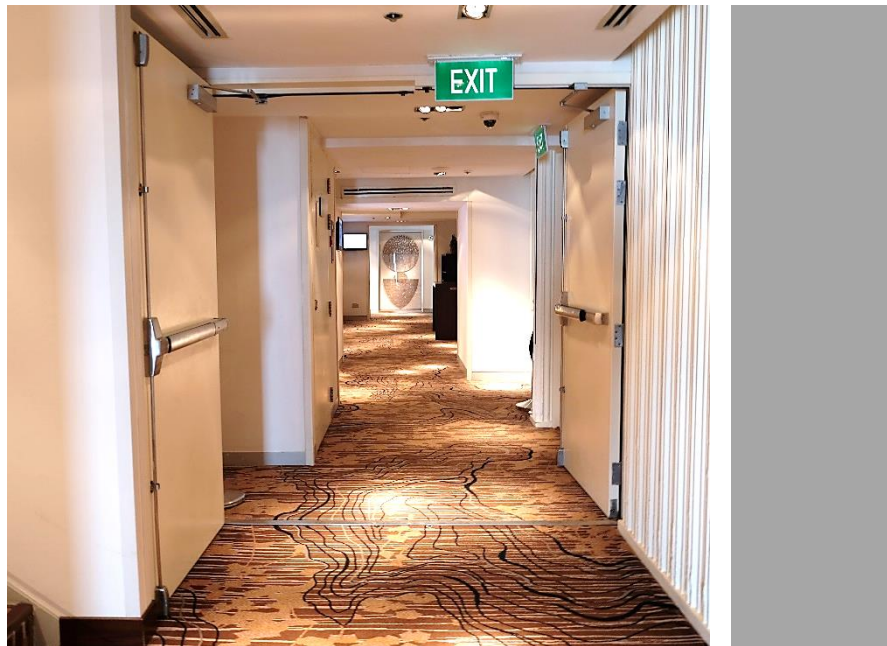

TACAM STEEL PTE LTD

Singapore: 541 Bt. Batok St 23, #07-00 Tacam Industrial Building, Singapore 659546. Tel +65 6665 7555; www.tacamsteel.com

Malaysia: B15-5 Jalan Selaman 1, Dataran Palma Off Jalan Ampang, 68000 Ampang, Selangor Darul Ehsan, Malaysia. Tel +603 4270 2267; Fax: +603 4270 2269